

IntelliFlo® VS+SVRS

Intelligent Variable Speed Pump



Reliable anti-body entrapment protection for your peace of mind

IntelliFlo VS+SVRS is the first pump with an integrated Safety Vacuum Release System (SVRS) which provides an important layer of entrapment protection.

Safety Features

- Includes a built-in controller with proprietary software that detects blockage and automatically shuts itself off within seconds.
- Meets ASME A112.19.17.2002 standards, thus complying with the Virginia Graeme Baker Pool Safety Act SVRS Requirements.
- No SVRS calibration required: the blockage detection/shut down function is pre-programmed into the software.
- Unlike other devices, IntelliFlo VS+SVRS pump's SVRS protection cannot be turned off.
- For added safety, if the SVRS becomes disabled, the pump will not run.
- Safety lock-out feature (password protected) prevents pump speed settings from being changed by unauthorized personnel.

The Virginia Graeme Baker Pool & Spa Safety Act of 2007—Summary

This new federal law was enacted to help prevent suction entrapment injuries and becomes effective December 19, 2008. The requirements for public swimming pools, spas, and wading pools are summarized below and must be met before these facilities can be operated after that date.

Drain Cover Requirements - New drain covers certified to ASME/ANSI A112.19.8—2007 must be installed.

Backup System Requirements - Suction piping for each pump must be inspected and will be considered in compliance with the federal law if: 1) no submerged drains connect to the pump, or 2) there are two drains at least 3 feet apart, or 3) there is a single “unblockable” drain. An unblockable drain includes a sump under the cover that is larger than 18 inches by 23 inches, or a channel type drain with a diagonal open area of at least 29 inches.

Single and two-drain systems less than 3 feet apart that fail to meet one of the above requirements must be updated by adding, 1) Safety Vacuum Release System (SVRS), 2) Suction-Limiting Vent System, 3) Gravity Drainage System, 4) Automatic Pump Shut-Off System, 5) Drain Disablement, or 6) Other Systems determined by Consumer Product Safety Commission to be equally effective. Another option is to split the single drain into a dual-drain system with at least 3 feet of separation.

For more information about the Virginia Graeme Baker Pool and Spa Safety Act and how to comply, review the U.S. Consumer Product Safety Commission's interpretation posted at: <http://www.cpsc.gov/phth/vgpsa.pdf>.

Two key technology innovations drive significant energy savings

IntelliFlo VS+SVRS pump includes exclusive, breakthrough motor technology and controllable, variable-speed technology that combine to drive down energy use and cost. And the savings potential may be measured in thousands of dollars over its long life.

First, the IntelliFlo VS+SVRS pump uses an exclusive permanent magnet motor—like those used in hybrid cars—in place of a traditional induction motor. Permanent magnet motors are fundamentally more energy efficient.

Second, the IntelliFlo VS+SVRS pump includes a variable speed capability, along with digital controls and proprietary software that allow custom programming of optimum pump speeds for specific tasks—filtering, heating, cleaning, spa jets, etc.

Here's just one comparative example:

Pump	Annual Kilowatts Use @ 24 hr/day Run Time	Annual Electric Cost @.15 Kwh	Savings Difference*
2 HP	19,272	\$2,891	
IntelliFlo VS+SVRS	9,654	\$1,448	\$1,443 or 50%

*Actual savings may vary based on plumbing size and length, pump model, service factor, and other hydraulic factors. Example reflects savings for an average 30,000 gallon commercial pool operating 24 hours per day at a flow rate sufficient to perform a minimum 6 hour turnover.

Why slower is better

The surprising secret to minimizing pump energy costs is to operate at the lowest speed needed to accomplish a job. It takes far less energy to move water slowly than quickly. Why? Because there's lower resistance in the filter, accessories and plumbing system. Even with only modest pump speed reductions, the effect on electricity usage can be dramatic. In fact, reducing pump motor speed by 25% actually reduces the power needed by 58% of what's consumed at the higher speed. A good analogy is your car: you get much better gas mileage at 30 mph than at 90 mph. The same is true with pool pumps—run slower to reduce energy used.



Traditional pumps' pre-set speeds are almost always greater than that needed to meet the health department turnover requirements.

With a variable speed pump, the optimum speed will almost always be lower than the pre-set, unchangeable speeds of older pumps. IntelliFlo VS+SVRS pump's eight settable, changeable speeds (ranging from 1100 to 3450 RPMs) mean you can program the exact flow requirements for each task, assuring the lowest energy use possible... adding to your savings. Plus with IntelliFlo VS+SVRS pump, you may be able to further reduce energy costs by reducing flow rates during non-pool use hours while maintaining 24 hour-a-day filtration... at a much lower cost. Check with your local health department for requirements in your area.



Engineered for exceptionally long life

IntelliFlo VS+SVRS pump's permanent magnet motor produces far less heat and vibration than traditional induction motors. This not only results in less stress and wear on pump components, but on other equipment, too. Exclusive load-sensing software provides nearly instant priming which saves energy and reduces wear and tear on the pump. Plus, built-in diagnostics protect the IntelliFlo pump from the most common causes of premature pump failure—loss of prime, overheating, freezing, and voltage irregularities. The result is you can expect dramatically longer life and an even greater return on your investment.

Other valuable features

IntelliFlo VS+SVRS pump anticipates and solves other pool operating challenges:

- Easy to program and monitor: simple push-button controls and clear LCD readouts make operation a cinch.
- Ability to set minimum and maximum speeds: IntelliFlo will only operate within the ranges you set to help assure safe operation and long equipment life.
- Built-in clock and timer: Obsoletes the need for an added time clock or expensive controller.

The only SVRS compliance solution that reduces operating costs

Don't just comply with the Virginia Graeme Baker Safety Act, upgrade your pool with the intelligent IntelliFlo VS+SVRS pump. This pump not only meets safety requirements, it provides longer, trouble-free service, and may save thousands of dollars in utility costs over its long life.

For more information on IntelliFlo VS+SVRS, contact your service provider, call Pentair Water Pool and Spa or visit www.svrspump.com today.

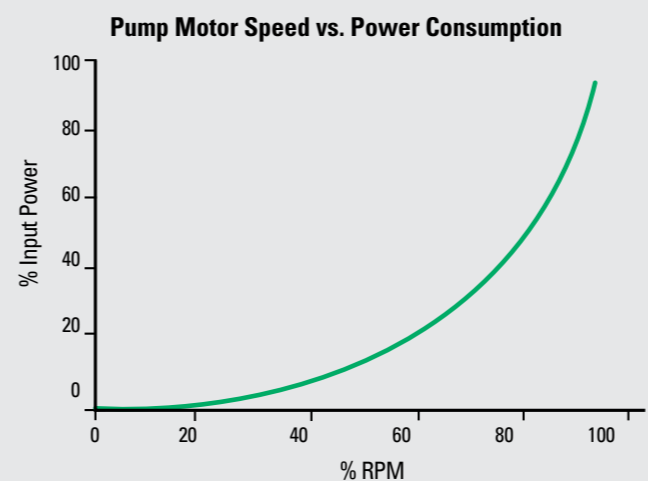

This graph shows the huge increase in energy consumption as pump speed increases. Slow down the pump and you cut energy costs dramatically.

IntelliFlo® VS+SVRS

Intelligent Variable Speed Pump

IntelliFlo® vs+svrs Pump

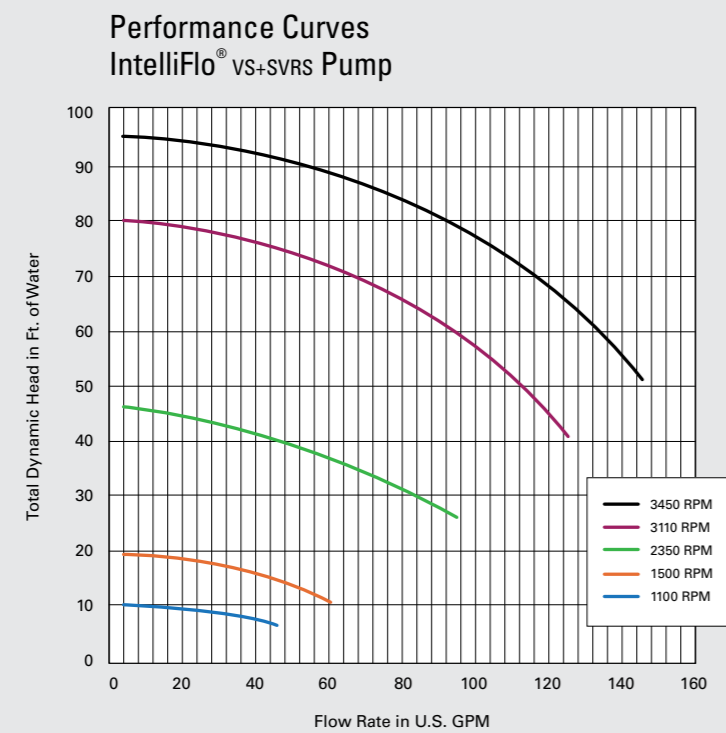
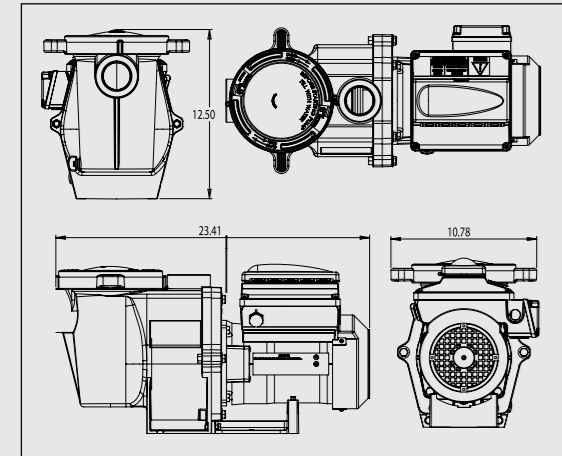

IntelliFlo® VS+SVRS

Intelligent Variable Speed Pump

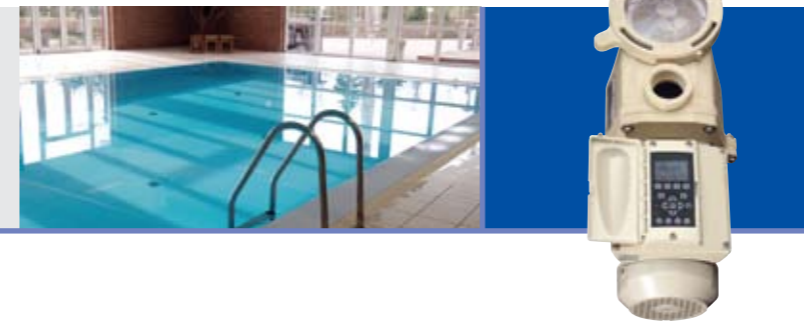

MATERIALS AND DESIGN

Pump Body

Volute type back pull out design for ease of working on impeller, diffuser and seal.

- **Port Size**
 - Inlet (Suction): 2 inch - 11 NPT
 - Outlet (Discharge): 2 inch - 11NPT
- **Material**
 - Glass Filled Polypropylene Thermoplastic with threaded brass inserts for maximum strength.
 - ¼ inch NPT drain plug of thermoplastic thumbscrew (no tool required) design on the strainer for winterizing.
- **Impeller**
 - Glass Filled Noryl enclosed design for corrosion prevention and maximum flow efficiency.
 - Threaded Brass Insert for maximum strength.
- **Diffuser**
 - Glass Filled Polypropylene Thermoplastic material with bronze impeller wear ring.
 - Patented FunnelFlo design for maximum efficiency.
- **Seal plate**
 - Glass Filled Thermoplastic material with threaded brass inserts for strength.
- **Mechanical Seal**
 - Type 6A mechanical seal
- **Base**
 - Glass Filled Polypropylene Thermoplastic with slotted holes for easy mounting.
- **Gaskets**
 - Buna rubber compression resistant
- **Bolts, Nuts, and Washers**
 - Stainless steel
- **Corrosion Prevention**
 - All thermoplastic pump for maximum hydraulic performance, noise reduction, and corrosion prevention.

Hair and Lint Strainer

- **Basket**
 - Polypropylene Thermoplastic Basket Colored White for easy debris removal.
 - 7.75 inch tall basket with large open area exceeding the requirements of NSF for maximum debris removal and efficiency.
- **Lid**
 - Clear "see thru" Polycarbonate Thermoplastic Lid for easy view into the basket area.
- **Lid Locking Ring**
 - Glass Filled Thermoplastic.
 - Cam and Ramp Design allows for quick and easy access to the basket.

Motor

- **Frame and Type**
 - NEMA 56 Frame Square Flange totally enclosed fan cooled.
 - Permanent magnet synchronous motor (PMSM).
- **Shaft**
 - DS 8018 Stainless Steel Construction
- **Thermal Overload Protection**
 - Thermal Overload Protection provided by the integral motor control.
- **Bearings**
 - Lubricated, double sealed, stainless steel, single row ball bearings.

Electrical

- 230 Volts, 1 phase, 16 amps maximum 50 or 60 Hertz
- Circuit Breaker Required: 20 amp, 2 pole, 230 Volts

Pump Maximum Thermal Limits

- Ambient Air Temperature: 130°F
- Liquid Temperature: 104° F

ENGINEERING SPECIFICATIONS

IntelliFlo® vs+svrs Pump

Recirculation pump shall be Pentair Series Model No. _____ self-priming centrifugal pump, _____ phase, 60 Hz.

General Notes

- Install pump in a cool, dry, well vented location away from pool heaters, and chemical storage.
- Pump should be firmly mounted with pipe supported to prevent vibration and undue operational noise.
- Allow 12" minimum clearance above lid for servicing.
- Allow 12" minimum clearance behind motor for servicing.
- Motor overheating may be caused by a voltage drop or excessive voltage. Be sure that wire size and voltage input is properly regulated.

Specifications

- The recirculation pump shall be a self-priming, centrifugal design with a hair and lint strainer as shown in the plans.
- The pump body and attached hair and lint strainer shall be constructed of non-corrosive 40% glass filled polypropylene materials, and close-coupled to an electric motor by means of a seal plate of the same material. The pump body shall have a single suction port with a 2" NPT on the hair and lint strainer. A discharge port of 2" NPT and a winterizing drain port of ¼" NPT shall be a part of the design.
- The pump shall be a back pull-out design to allow servicing without disturbing piping. The pump shall have a 40% glass filled polypropylene diffuser to aid in priming and it shall contain a bronze wear ring for the impeller. The impeller shall be of the closed type and Noryl®, non-overloading at any point on the performance curve. The mechanical shaft seal shall be constructed of ceramic and carbon seal faces, with stainless steel, brass and Buna N materials in the spring bellows portion.

The impeller shall be secured to the motor shaft by means of a molded in brass insert and a stainless steel locking screw into the end of the motor shaft. The pump shall be capable of operating at up to 42 psi, 104° F continuous water temperature, 130° F ambient air temperature.

- The electric motor coupled to the pump shall be of the NEMA 56 Frame permanent magnet synchronous motor (PMSM) totally enclosed fan cooled series with stainless steel shaft and double shielded, single row, lubricated stainless steel ball bearings. Motors shall be continuous duty rated at 130° F (or better) ambient and be suitable for outdoor installation.
- The pump motor shall be a NEMA 56 Frame Square Flange, totally enclosed fan cooled, PMSM for service on a 230 volt electric supply. The pump shall be rated for _____ GPM at _____ TDH. The pump shall be tested and certified by a nationally recognized testing laboratory to conform to National Sanitation Foundation Standard 50.
- The drive meets all CE and FCC requirements for line noise.

Hair and Lint Strainer

- The buna strainer shall consist of a polypropylene body, poly carbonate cover with O-ring seal, and Cam and Ramp™ locking ring, and a strainer basket of mineral reinforced polypropylene material.
- The strainer body shall be 2" NPT suction. The strainer body shall have a removable drain plug for winterizing.
- The strainer basket shall be securely positioned below the suction inlet of the trap, with access for inspection and cleaning through a removable trap body lid. The trap body lid shall be secured by means of a Cam and Ramp™ locking ring.



1620 Hawkins Avenue
Sanford, NC 27330
Phone: 800-831-7133 Fax: 800-284-4151
www.pentairpool.com

©2008 Pentair Water Pool and Spa, Inc. All rights reserved.



IntelliFlo® VS+SVRS Intelligent Variable Speed Pump

The ONLY way to comply with new federal anti-body entrapment standards and save money

There's simply no better way to add a Safety Vacuum Release System (SVRS) to your public pool or spa than with the new IntelliFlo® vs+svrs pump. It helps prevent suction entrapment and also provides value that no other solution can.

While other safety solutions represent an added cost, IntelliFlo is an investment that may potentially save thousands of dollars in energy costs over its long life.

Standard Features

- Replaces 3HP or smaller pumps
- Meets ASME A112.19.17.2002 standards for anti-body entrapment protection
- Onboard intelligence detects blockage and automatically shuts pump off within seconds
- Exclusive breakthrough motor technology provides energy savings while being safety compliant
- 8 settable, changeable speeds ranging from 1100 to 3450 RPMs
- NSF certified and UL and ETL Listed