



## EQ Series®

### High Performance Commercial Pump



***For commercial and high-end residential swimming pools and other water applications. Available in flows to 800 GPM, and from 3 to 15 HP.***

EQ Series commercial pumps are designed for maximum efficiency and quiet operation in every detail. They are the only non-corrosive, all plastic pumps designed exclusively for the commercial pool and water applications market. EQ Series Impellers are manufactured for true breakthrough performance, allowing for lower loads and longer motor life. Available with and without a 6" x 6" strainer pot.

#### Standard Features

- Close coupled for quiet, stable flow operation.
- Lightweight for easy, one-man installation.
- Cam and Ramp™ locking ring design with clear lid for added service convenience.
- 6" suction and 4" discharge with strainer pot.
- Closed impeller for long life and durability.
- Available in single- and three-phase models.
- Self-priming under NSF standards; NSF listed.

## Performance curves EQ Series®

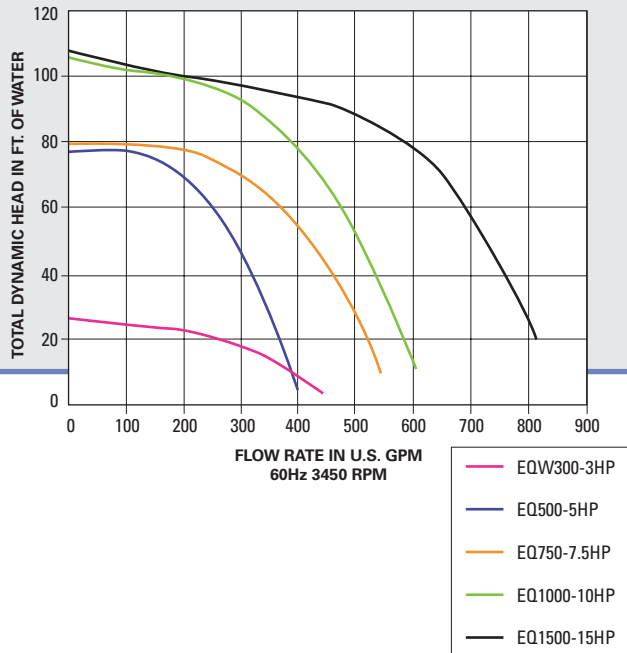

## Performance curve EQ Series® Waterfall™ Pump

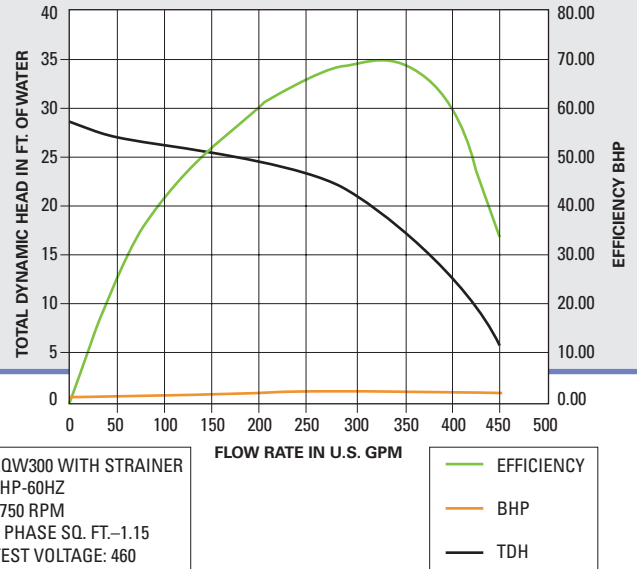

For detailed efficiency curves for each model, please contact the factory.

## Materials and Design

### PUMP BODY

Volute type, back pull-out design.

- **Port Size**  
6" – ANSI 150 bolted flange suction port.<sup>1</sup>  
4" – ANSI 150 bolted flange discharge port.<sup>1</sup>
- **Material - Volute & Motor Adapter**  
Noryl®.
- **Impeller**  
Noryl® enclosed design.
- **Base**  
6061 Aluminum design, slotted for mounting ease.
- **Corrosion Prevention**  
All-plastic pump for maximum hydraulic performance and corrosion prevention.

### HAIR AND LINT STRAINER

- **Material**  
Separate bolt-on Noryl® body with plastic basket, Lexan® lid, and stainless steel bolts.
- **Size**  
6" ANSI 150 bolted flange suction and discharge ports.

<sup>1</sup> Use ANSI class 150 plastic flange and 1/8" thick class 150 full flange gasket to make connection.

## PUMP MAXIMUM LIMITS

Liquid Temperature: 104°F  
Ambient Air Temperature: 104°F

## MOTOR

Standard JM type.

- **Frame Size**  
NEMA "C" flange. 230/460V are open drip-proof design.
- **Shaft**  
303 Stainless steel construction.
- **Design**  
3 to 15 HP, 3500 RPM, JM open drip-proof, continuous duty, three-phase and single-phase (5 and 7-½ HP only).
- **Bearings**  
Double shielded, single row, deep groove type, permanently lubricated.
- **Thermal Overload Protection**  
All models require external thermal overload protector.

## ELECTRICAL

- **Power Supply Required**  
Three-phase pumps are 208-230/460. 3, 5 and 7-½ HP single-phase models are available in 230V, 60 Hz. only.



## EQ Commercial Pump With Strainer Pot 6" x 6"

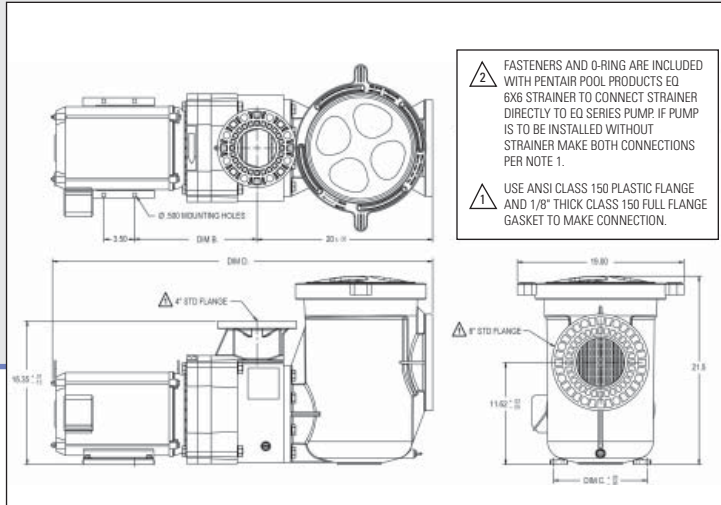

## EQ Commercial Pump Without Strainer Pot

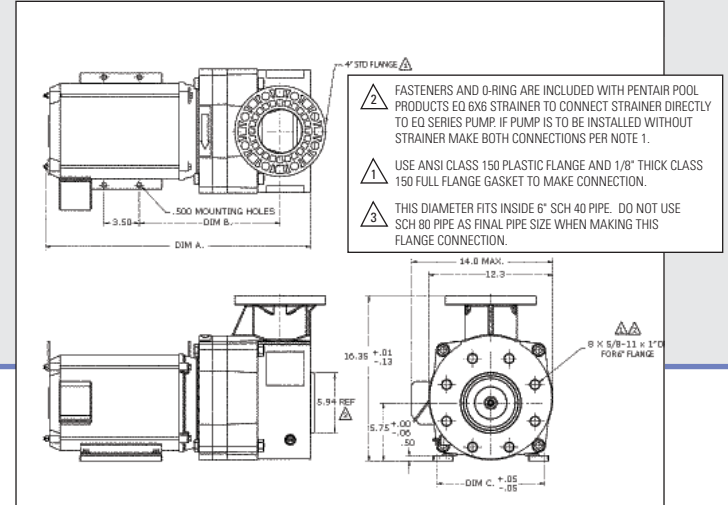

## EQ Commercial Pump With Strainer Pot 6" x 6"

Part #	Description	Voltage	Amps	Phase	HP	Wt	Dim. A	Dim. B	Dim. C	Dim. D
340026	EQW 300 Waterfall	115/230	38/19	1	3	97	26.62	10.03	7.5	43.590
340027	EQWK 300 Waterfall	208-230/460	8.4-7.9/3.9	3	3	77	23.12	10.16	7.5	40.094
340030	EQ500	230	19.6	1	5	97	26.62	10.03	7.5	43.590
340031	EQK500	208-230/460	13.5-12.3/6.2	3	5	77	23.12	10.16	7.5	40.094
340032	EQ750	230	30.4	1	7.5	132	27.53	10.78	8.5	44.590
340033	EQK750	208-230/460	20.1-18.3/9.1	3	7.5	87	24.50	10.16	7.5	41.560
340034	EQK1000	208-230/460	27.1-24.3/12.2	3	10	117	26.31	10.78	8.5	43.290
340035	EQK1500	208-230/460	40.0-36.0/17.8	3	15	132	26.31	10.78	8.5	43.290

340013 Strainer Pot Assembly including Strainer, Lid, Basket, and Hardware

## EQ Commercial Pump Without Strainer Pot 6" x 4"

Part #	Description	Voltage	Amps	Phase	HP	Wt
340014	EQW 300 Waterfall	115/230	38/19	1	3	97
340016	EQWK 300 Waterfall	208-230/460	8.4-7.9/3.9	3	3	77
340019	EQ500	230	19.6	1	5	97
340020	EQK500	208-230/460	13.5-12.3/6.2	3	5	77
340021	EQ750	230	30.4	1	7.5	132
340022	EQK750	208-230/460	20.1-18.3/9.1	3	7.5	87
340023	EQK1000	208-230/460	27.1-24.3/12.2	3	10	117
340024	EQK1500	208-230/460	40.0-36.0/17.8	3	15	132

# EQ Series® Pumps

## High Performance Commercial Pumps



### EQ SERIES PUMP

- Recirculation pump shall be Pentair EQ Series Model No. \_\_\_\_\_ self-priming centrifugal pump, \_\_\_\_\_ phase, 60 Hz.

### GENERAL NOTES

- Install pump in a cool, dry, well vented location away from pool heaters, and chemical storage.
- Pump should be firmly mounted with pipe supported to prevent vibration and undue operational noise.
- Allow 12" minimum clearance behind motor for servicing.
- Motor overheating may be caused by a voltage drop or excessive voltage. Be sure that wire size and voltage input is properly regulated.

### SPECIFICATIONS

- The recirculation pump shall be a self-priming, centrifugal design with a hair and lint strainer as shown in the plans.
- The pump body, seal plate, and attached hair and lint strainer shall be constructed of non-corrosive Noryl® materials, and close-coupled to an electric motor by means of an adaptor of the same material. The pump body shall have a single suction port with a 6" ANSI 125 bolt flange to the hair and lint strainer. A centerline discharge port of 4" ANSI 125 bolt flange and a winterizing drain port of ¼" NPT shall be a part of the design.
- The pump shall be a back pull-out design to allow servicing without disturbing piping. The pump shall have a Noryl® diffuser to aid in priming and it shall contain a replaceable bronze wear ring for the impeller. The impeller shall be of the closed type and Noryl®, non-overloading at any point on the performance curve. The mechanical shaft seal shall be constructed of ceramic and carbon seal faces, with stainless steel, brass and Buna N materials in the spring bellows portion. The impeller shall be secured to the motor shaft by means of a stainless steel key and locking screw into the end of the motor shaft. The pump shall be capable of operating at up to 50 psi, 104°F continuous water temperature.
- The electric motor coupled to the pump shall be of the NEMA series JM construction with stainless steel shaft inside a removable shaft sleeve of 300 series stainless steel. The motor shall be of an open, drip-proof design (unless otherwise specified) with double shielded, single row, deep groove ball bearings. Motors shall be continuous duty rated at 40°C (or better) ambient and be suitable for outdoor installation.



- The pump motor shall be a \_\_\_\_\_ HP, \_\_\_\_\_ phase, 60 Hz, 3450 RPM for service on a \_\_\_\_\_ volt electric supply. The pump shall be rated for \_\_\_\_\_ GPM at \_\_\_\_\_ TDH. The pump shall be tested and certified by a nationally recognized testing laboratory to conform to National Sanitation Foundation Standard 50.

### HAIR AND LINT STRAINER

- The pump strainer shall consist of a Noryl® body, Lexan® cover with O-ring seal, and Cam and Ramp™ locking ring, and a strainer basket of mineral reinforced polypropylene material.
- The strainer body shall be 6" ANSI 150 bolt flanged suction and discharge ports. The strainer body shall have a removable drain plug for winterizing.
- The strainer basket shall be securely positioned below the suction inlet of the trap, with access for inspection and cleaning through a removable trap body lid. The trap body lid shall be secured by means of a Cam and Ramp™ locking ring. The strainer basket shall have a perforation which in total open area is 98 square inches.



**Pentair Water**  
Commercial Pool and Spa™

1620 Hawkins Avenue

Sanford, NC 27330

Phone: 800-831-7133

[www.pentairpool.com](http://www.pentairpool.com)