

LEGEND® PLATINUM

Pressure Side Pool Cleaner



Installation Guide

IMPORTANT SAFETY INSTRUCTIONS
READ AND FOLLOW ALL INSTRUCTIONS
SAVE THESE INSTRUCTIONS

Customer Service

If you have questions about ordering Pentair replacement parts, and pool products, please use the following contact information:

Customer Service (8 A.M. to 5 P.M. — Eastern and Pacific Times)

Phone: (800) 831-7133

Fax: (800) 284-4151

Technical Support

Sanford, North Carolina (8 A.M. to 5 P.M. — Eastern Time)

Phone: (919) 566-8000

Fax: (919) 566-8920

Moorpark, California (8 A.M. to 5 P.M. — Pacific Time)

Phone: (805) 553-5000 (Ext. 5591)

Fax: (805) 553-5515

Web site

visit www.pentairpool.com and www.staritepool.com to find information about our products

© 2005 Pentair Water Pool and Spa, Inc. All rights reserved.

This document is subject to change without notice.

1620 Hawkins Ave., Sanford, NC 27330 • (919) 566-8000

10951 West Los Angeles Ave., Moorpark, CA 93021 • (805) 553-5000

Trademarks and Disclaimers. The *Pentair Water Pool and Spa logo* is a trademark of Pentair Water Pool and Spa, Inc. The *Legend Platinum logo* is a registered trademark of Pentair Water Pool and Spa, Inc. Other trademarks and trade names may be used in this document to refer to either the entities claiming the marks and names or their products. Pentair Water Pool and Spa, Inc. disclaims any proprietary interest in trademarks and trade names other than its own.

LEGEND[®] PLATINUM

LL105PM / LL105PMG
LL105PMTGG / LL105PMTWW
LL105PMTRW / LL105PMTYW

Important Information:

The Legend[®] Platinum automatic pool cleaner comes ready to connect into a female threaded 1-1/2" line, dedicated to our Universal Booster Pump. Also, if you have a chlorinator, solar system or other air inducing equipment, contact our Technical Support Department at 1-800-831-7133 before you install the Legend[®] Platinum. (See diagram on page 2).

The following are important facts to remember before installing and operating the Legend[®] Platinum.

1. Always disconnect the Legend[®] Platinum from the pool wall when cleaning or back washing the pool filter.
2. After cleaning or back washing, let the filtration system run for at least five minutes before reconnecting the Legend[®] Platinum.
3. New plumbing lines should be flushed out before installing the Legend[®] Platinum.
4. The Legend[®] Platinum should not be used to remove plaster dust in new pools.
5. Always remove the Legend[®] Platinum before swimmers enter the pool.
6. Always handle the Legend[®] Platinum with care. Do not let children or pets play with the unit: it is not a toy.
7. Always pick up the Legend[®] Platinum by the Vacuum Tube especially when lifting the unit out of the water.
8. Unless checking the wheel RPM, do not handle the Legend[®] Platinum while it is operating.
9. Always remove the Legend[®] Platinum from the pool before chemical shock treatments. As a rule, any pool water that is unsafe for swimming is unsafe for the Legend[®] Platinum.
10. Carefully cut the feed hose following the instructions on [Page 3](#).

By following these simple guidelines, you can help protect against injury and prolong the life of your Legend[®] Platinum.

Before the Legend[®] Platinum is installed, please take a moment to record the serial number. This number is located on your warranty card and on the back of the Legend[®] Platinum near the rear jets. You will be asked for this number when you contact our Technical Support Department.

SERIAL # _____

TABLE OF CONTENTS

I. Introduction	1
A. Thank You for Choosing the Legend® Platinum.....	1
B. What to Expect from the Legend® Platinum.	1
II. Installation Instructions	2
A. Legend® Platinum Components	2
B. Pool Connections	2
C. Booster Pump Installation	2
D. Installing the Twist Lock Pressure Relief Valve (Wall Fitting)	3
E. Cutting the Feed Hose	3-6
F. Checking Operation	7
G. Fine Tuning the Legend® Platinum.....	7
1. Thrust Jet Adjustment	7
2. Sweep Hose Adjustment	7
3. Checking Wheel RPM	8
III. Operation & Periodic Maintenance	9
A. Connecting/Disconnecting the Legend® Platinum	9
B. Turning the Legend® Platinum On/Off	9
C. Cleaning the Sand & Silt Bag	9
D. Periodic Maintenance	9
1. Wall Fitting Screen	9
2. Tires & Bearings	10
3. Roller Rings	10
4. Debris Bags	10
5. Sweep Hose	10
6. Debris Valve	10
E. Back Washing the Pool Filter	10
F. Storage and Winterizing	10
G. Accessories	10
1. Sweep Hose Weight	10
2. Leaf Bag	10
IV. Troubleshooting	11-12
Legend® Platinum Parts List	13-14
Legend® Platinum Exploded View	15

I. Introduction

A. Thank You for Choosing the Legend® Platinum Pool Cleaner

Congratulations on the purchase of your new automatic pool cleaner. The Legend® Platinum is designed to give you years of dependable and efficient service. With the Legend® Platinum, you and your family will spend more time relaxing and enjoying your pool and less time cleaning it.

The Legend® Platinum has been designed and built with time proven features and patented innovations to create an automatic pool cleaner that will give you years of dependable service. The Legend® Platinum is built with pride in the U.S.A., by people who care about the product using state of the art materials and backed by a limited warranty that protects against defects in parts and construction.

Like any mechanical device, the Legend® Platinum requires some preventative maintenance and the replacement of certain working parts. We recommend that you have your Legend® Platinum checked annually. For best results have your Legend® Platinum installed by a qualified swimming pool professional.

For pool owners with plumbing and mechanical experience, installation instructions are included in this manual.

Please put safety first! Be sure to take your Legend® Platinum out of your pool and store it carefully in a shaded area before anyone enters the pool.

B. What to Expect from the Legend® Platinum

When operating correctly, the Legend® Platinum will travel randomly throughout the pool, vacuuming and sweeping the bottom. The climbing ability of the Legend® Platinum is dependent on the pool's shape. It will climb better in pools without sharp angles or curves in the transition from the pool floor to the pool wall.

The Legend® Platinum comes equipped with a **Wall Fitting (Part # EW22-White, Part # LLW22PM-Gray) that features a Twist Lock Automatic Pressure Relief Valve**. If the Legend® Platinum is receiving too much water pressure to the unit, the relief valve will automatically reduce water pressure.

Approximately every three minutes and 30 seconds, the Legend® Platinum will go into a back up mode. At this time, the Back Up Valve will pull the Legend® Platinum away from problem areas.

The Sweep Hose operates in a gentle sweeping motion to prevent debris from becoming trapped in hard to reach corners of the pool.

II. Installation Instructions

A. Legend® Platinum Components

The Legend® Platinum Box Contains:

1. Cleaner Head
2. Sand & Silt Bag
3. Sweep Hose
4. Complete Feed Hose
 - a. 1 - 8½ in. hose
 - b. 2 - 10 ft. long hoses
 - c. 1 - 30 in. soft hose/1 - 7½ ft. soft hose
 - d. 10 - Floats
 - e. 3 - Swivels
 - f. 1 - Back-Up Valve
 - g. 10 - Mender Nuts
 - h. 1 - Wall Fitting complete

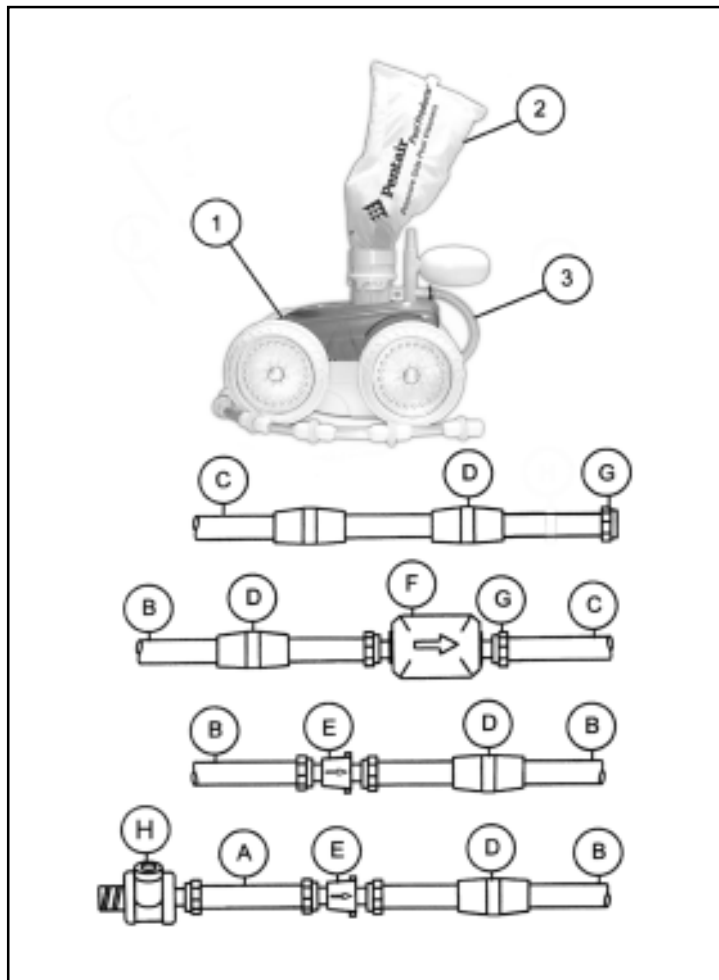

B. Pool Connections

The Legend® Platinum comes equipped to connect to a female threaded 1-1/2 in. line, dedicated to our Universal Booster Pump.

Also, if the pool doesn't have a dedicated cleaner line please contact our Technical Support Department at 1-800-831-7133.

C. Booster Pump Installation

If you already have a 3/4 horsepower booster pump installed at your equipment pad and it is operational, skip this section and proceed to Installing the Twist Lock Pressure Relief Valve (Wall Fitting).

Detailed booster pump installation instructions are packaged separately in our booster pump box. Please follow these instructions carefully.

The booster pump is not self-priming and needs to be fed with water taken from the pool filter before any type of in-line chlorinator. See figure below.

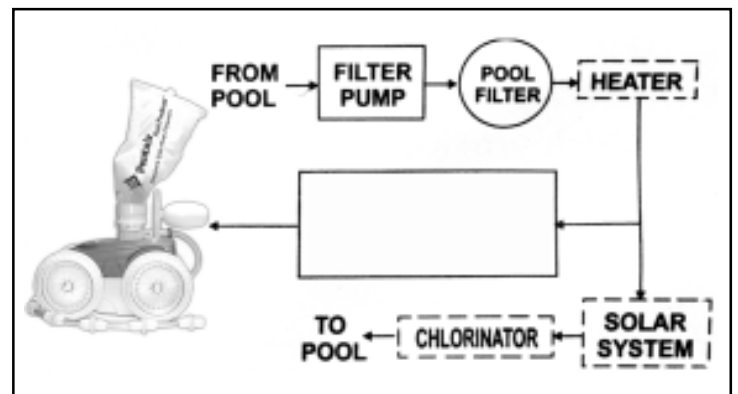

D. Installing the Twist Lock Pressure Relief Valve (Wall Fitting)

1. Take out any existing pool cleaner and/or wall fitting.
2. Turn on the filtration pump and booster pump, flush out the plumbing line.
3. Turn off filter pump and booster pump.
4. Remove the Wall Adapter from the Wall Fitting and screw Adapter by hand into the dedicated line. Turn until tight.

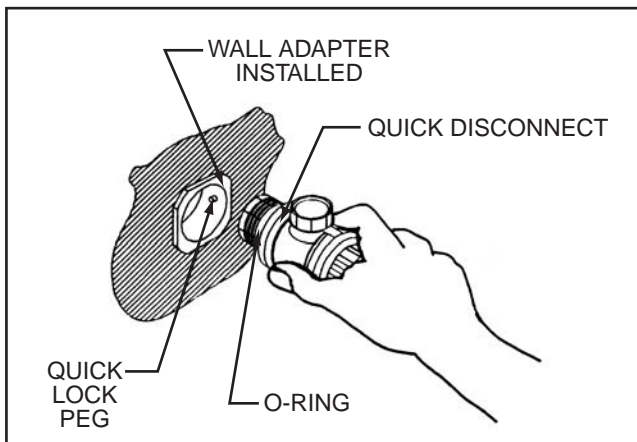

5. Take the Wall Fitting and Twist Lock the Wall Fitting into the Wall Adapter 1/4 turn and pull out, to a snug fit. Once the Wall Adapter is secure, you can now twist lock and unlock to remove Wall Fitting with ease from the Wall Adapter.

E. Cutting the Feed Hose

The Hose assembly comes in 5 sections now covering approximately 30 ft. of the pool, which provides ample hose for most residential pools. The Back-Up Valve is now 30 in. from the head cleaner and should always remain this distance. For larger pools [see #14 on page 6](#) for instructions on **Adding Additional Feeder Hose**.

1. Take Feeder Hose out of box (it will be approximately 30 feet long). Before installing the unit, you should lay the feed hose out straight in the sun, (for one day if possible). The hose has been curled up in the box and sometimes will go around in a circle. If this happens, take the first or second section of hose from the wall and reverse it, (turn it around). You might have to reverse both sections to correct the problem. Make sure the feed hose is cut and installed properly.
2. Measure how deep your pool is by using your telepole or the clear end of the feeder hose. Cut the clear (soft) hose equal to the depth of your pool. (Hint: the grate or domed main drain at the bottom is usually the deepest point.)

Example: The clear (soft) hose is 10 ft. long, if the pool is 8½ ft. deep, cut 1½ ft. off of the clear (soft) hose. If the depth is greater than 10 ft., do not cut the clear (soft) hose.

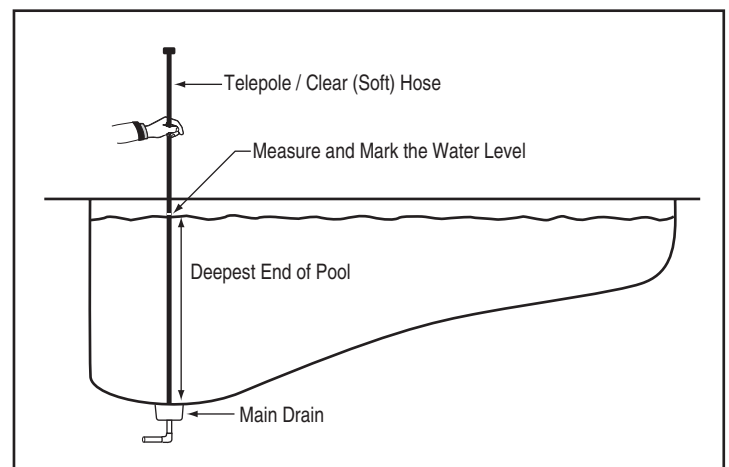

EXAMPLE OF HOSE ASSEMBLY BEFORE CUTTING TO LENGTH

STEPS

1. With the feed hose assembly attached to the pool wall, hold the feed hose assembly by the opposite end with the clear hose and walk the perimeter of the pool to locate the farthest point on the perimeter from the wall fitting without stretching the hose assembly.
2. Measure the distance that the hose assembly extends beyond the pool perimeter farthest point located in **Step 1** — (7½ ft. in this example).
3. Cut half of the length obtained from **Step 2** — (3¾ ft. in this example), equally from each of the 10 foot lengths of white or grey hose on either side of the marked swivel.

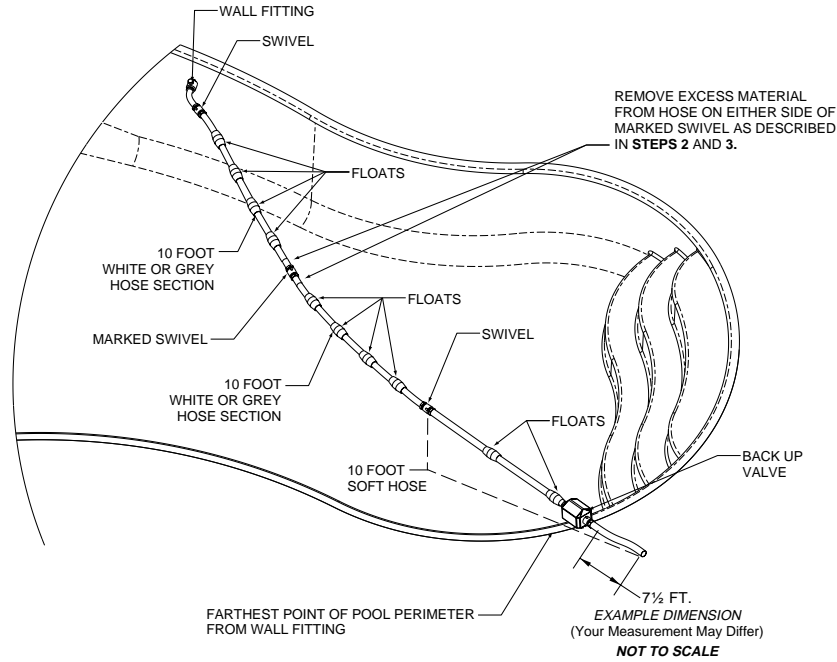

EXAMPLE OF FINISHED HOSE ASSEMBLY AFTER CUTTING TO LENGTH

STEPS

4. Reassemble the hoses using the supplied mender nuts as shown in **FIGURE 1**.
5. Your complete finished hose assembly should look like this. The end of the 30 inch clear hose should reach just to the furthest edge of the pool perimeter as shown.

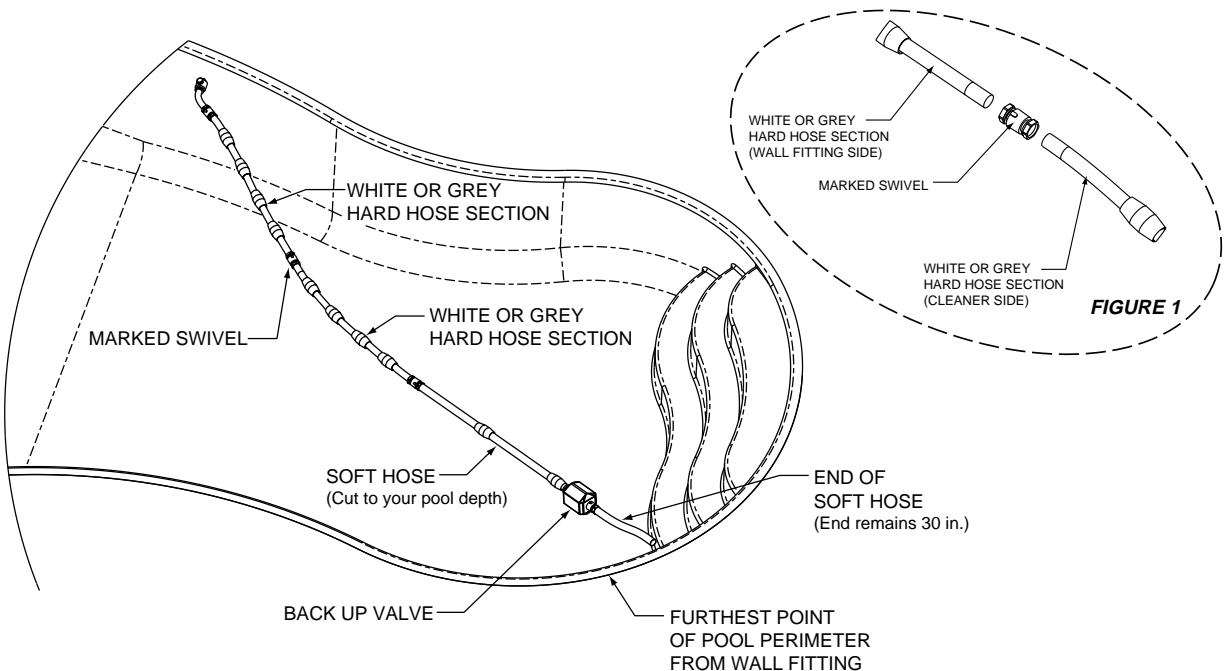

E. Cutting the Feed Hose - (cont.)

- Lay the telepole next to the clear (soft) hose. If the clear (soft) hose is longer than the mark on the telepole, cut the excess from the end attached to the white (hard) hose. Do not cut off the float. Leave the first float in position next to the Back-Up Valve. Place the second float midway between the first float and the Hose Swivel.

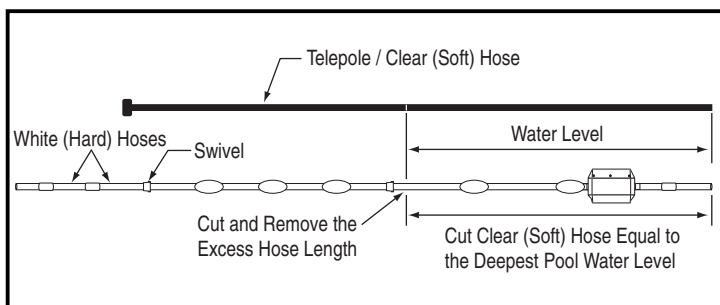

- Attach feed hose to the wall fitting and attach to the pool wall. Hold the end of the 30 in. clear (soft) hose and walk the perimeter of the pool keeping the hose straight (do not stretch hose) to find the farthest point of the pool from the wall fitting.
- Measure the excess length between the farthest point of the pool from Wall Fitting and the end of 30 in. clear (soft) hose.
- Half of this measured length to be **cut equally from the 10 ft. long hoses next to the Marked Swivel**. (Example: Half of 6 ft. = 3 ft. each). If you are cutting more than 2 ft. off the hoses, remove the floats next to the Marked Swivel from both hoses. See Figures on [page 4](#).

- Re-assemble the hoses and the swivel using mender nuts (see Figure below, Step 1). Put mender nut on swivels first, then push hose over swivel (see Figure below, Step 2). Rotate mender nut over hose clockwise until tight. **Note: Keep as many floats as possible on the long feed hoses, spaced evenly apart to hold hose up on top of water.**

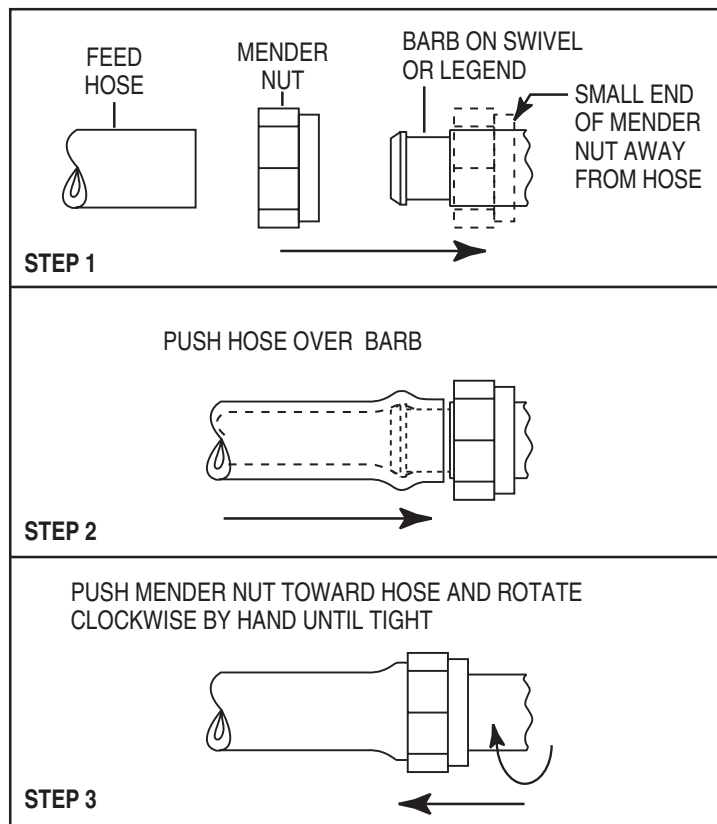

E. Cutting the Feed Hose - (cont.)

8. When cutting hoses, please use strong scissors or a sharp knife. Be sure to slide the floats out of the way when cutting hose.
9. Put extra mender nut on the Legend® Platinum mast and push soft hose gently over mast at 1/2 in., turn mender nut around soft hose tight.

Note: The Back-Up Valve still should be 30 in. from the head of the cleaner.

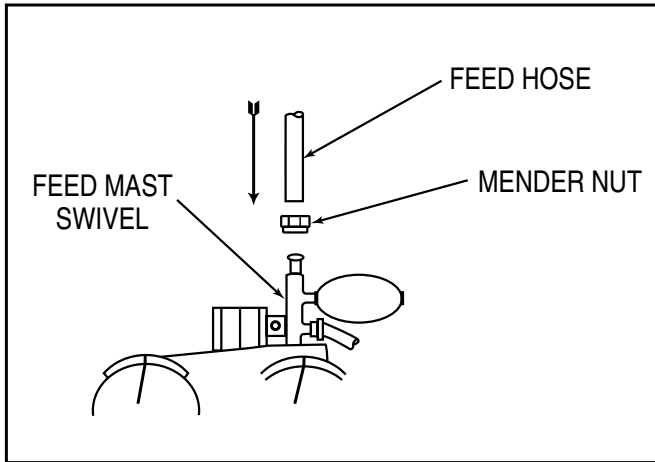

10. Now take the bag, EU16, out of the box and firmly twist lock the bag onto the top of the Legend® Platinum throat over rubber debris valve.
11. Review and check list: Hoses cut properly and floats evenly spaced. Mender nuts tight around swivels, back up valve, Legend® Platinum mast and wall fitting. Make sure wall fitting is securely locked into place.

12. Lower your complete Legend® Platinum assembly into your pool carefully. It should look like figure below.

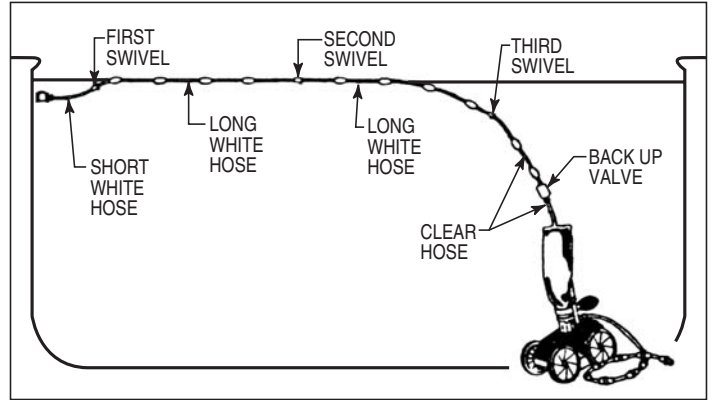

13. Go back to your equipment and turn filter pump on first (wait 30 seconds to force air out of the hose), then turn booster pump on.
14. For large pools requiring more hose length you will need to purchase one (1) additional hose (LLD45-White or LLD45PM-Gray), four (4) floats (ED10P-White or LLD10PM-Gray), one (1) swivel (ED05-White or LLD05PM-Gray), and two (2) mender nuts (ED15-White or LLD16PM-Gray). Attach extra hose between long hoses using floats, swivel and mender nuts. Divide extra hose overage by three (3) this time to keep all hoses the same length.

F. Checking Operation

When operating correctly, the Legend® Platinum will travel in a random pattern throughout the pool, vacuuming and sweeping the bottom. The climbing ability of the Legend® Platinum is dependent on the pools structure and water flow coming into the pool. It will perform more efficiently in pools without sharp angles or curves in the transition from the floor of the pool to the wall.

The Legend® Platinum comes with a Twist Lock Pressure Relief Valve (Wall Fitting). If the Legend® Platinum is receiving too much water pressure, the Relief Valve in the Wall Fitting will release the excess water pressure.

Approximately every three minutes and 30 seconds the Legend® Platinum will go into a back-up mode. The Back-Up Valve cycle time, while in the back-up mode, is approximately 30 seconds, pulling the Legend® Platinum from problem areas.

New Back-Up Valve Information:

The Back-Up Valve Insert (#MBUVP) which is slid into the slot over the jet of the valve. This is secured with a stainless steel screw (#VX-9) as show in the diagram. The insert will be set from the factory with the smaller (1/4") hole over the opening of the jet. The smaller hole is used for the Platinum cleaner. If you change the insert to the larger (3/8") hole, the Back-Up Valve will have decreased jet pressure and possible not pull the unit backwards.

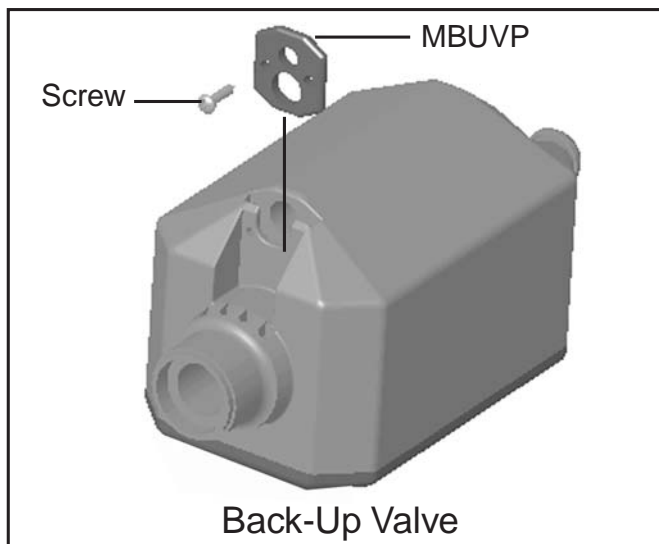

If the Legend® Platinum does not travel to all areas of the pool, turn off the booster pump and pool filtration pump and make the necessary adjustments from the instructions in the next section.

G. Fine Tuning the Legend® Platinum

1. Thrust Jet Adjustment

There are Thrust Jets located in the back of the Legend® Platinum. These Thrust Jets alter the direction of the cleaner. The factory standard position for the jets are: Left jet set slightly to the right and Right jet straight out.

(See illustration below.)

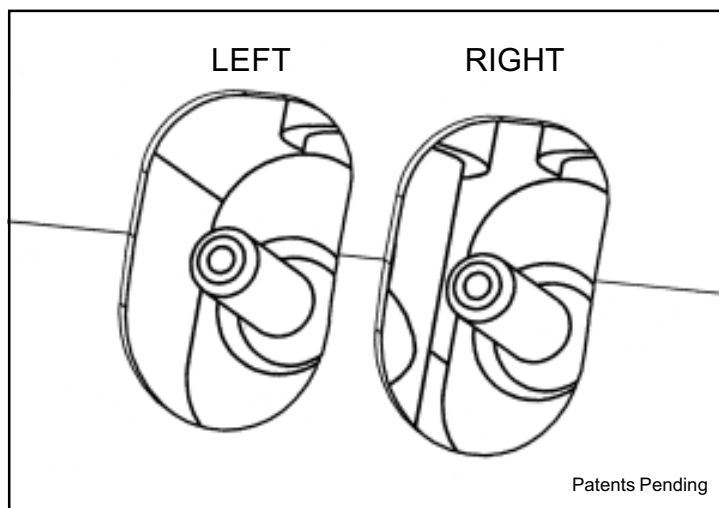

2. Sweep Hose Adjustment

The Sweep Hose operates in a gentle sweeping motion to prevent debris from becoming trapped in hard to reach corners of the pools. To increase or decrease the motion of the Sweep Hose, there is an adjustment screw located on the Feed Mast Barb below the Ballast Float. Turning the screw clockwise will decrease the motion and counter clockwise to increase the motion of the Sweep Hose.

3. Checking Wheel RPM

To determine whether the Legend® Platinum is receiving the proper water pressure, turn off the booster pump, pool pump and carefully remove the Legend® Platinum from the pool.

Mark the front drive Tire/Wheel with a marker, or use the Logo located on the side of tire as a marker to count the rotations of the wheel per minute.

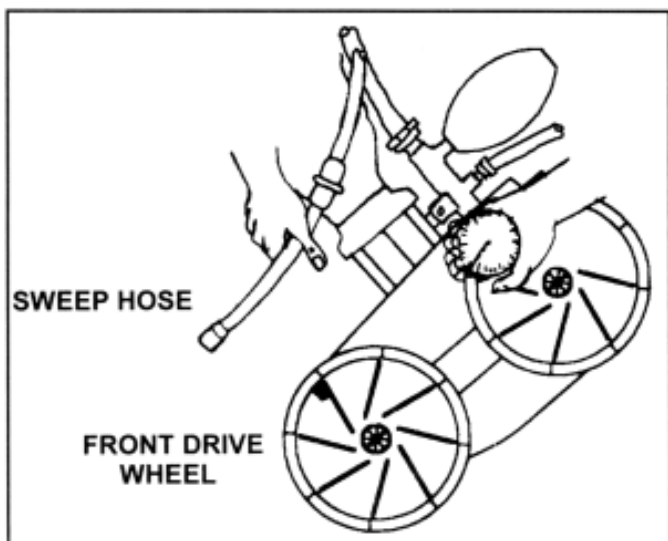

Have someone turn on pool pump and then booster pump while you place the Legend® Platinum in the pool just beneath the water surface. (Be sure to hold onto the Sweep Hose to avoid getting wet).

Count the rotations of the marked wheel for exactly one minute. (Be sure the Back-Up Valve isn't cycling at this time). The rotations will give you the Revolutions Per Minute, (RPM).

For proper performance, the Legend® Platinum operates between 28-32 RPM. If the RPM is below 28 then call your local Pool Professional or contact our Technical Support Department at 1-800-831-7133.

If the RPM is more than 32, at the Wall Fitting unscrew the Pressure Valve slowly until the RPM falls between 28-32.



If you have any additional questions, please contact our Technical Support Department @ 1-800-831-7133.

III. Operation/Periodic Maintenance

A. Connecting/Disconnecting the Legend® Platinum

Turn off booster pump and pool pump. Then take the Wall Fitting and twist lock the Wall Fitting clockwise into the Wall Adapter. To disconnect the Legend® Platinum, unlock and twist counter clockwise. The Wall Adapter should remain in the pool wall.

B. Turning On/Off the Legend® Platinum

The Legend® Platinum operates off the booster pump coming from the equipment pad, and can be turned on or off by merely turning on/off your booster pump time clock.

C. Cleaning the Sand & Silt Bag

Carefully unlock the debris bag from the vacuum tube and open the Velcro® Brand Fastener closure at the top of debris bag and dump debris.

If you have a lot of debris in your pool, especially after a storm, you can run your Legend® Platinum in two shorter cycles per day and empty the debris bag between cycles.

Reconnect the debris bag to the vacuum tube. Do NOT over turn.

If the Velcro® Brand Fastener strip on top of the debris bag does not stay secure, rinse well, let it dry and clean with a stiff brush.

A Helpful Hint: It is easier to empty the debris bag when it is dry. A second bag may be used while the full debris bag is drying.

It's best to empty the debris bag when it becomes half full. The Legend® Platinum will have better performance if the bag is not overloaded.

D. Periodic Maintenance

The following parts are wear items that should be checked, maintained or replaced as needed. Wear items are considered any working or moving part(s) being worn due to the use of the cleaner. Wear items are not covered under warranty.

1. Wall Fitting Screen

Inside the wall fitting is a filter screen that acts as a secondary filter. This screen is to keep debris that is passed by the pool filter out of the Legend® Platinum. Running the Cleaner without the filter screen can damage the Legend® Platinum and will void the warranty.

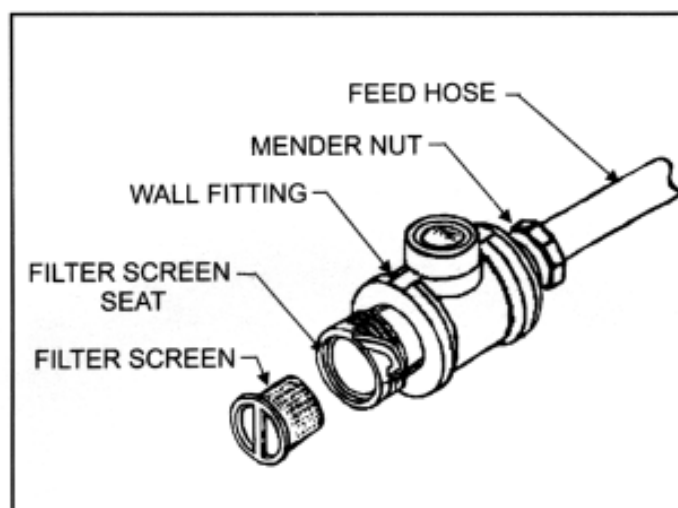

A continuous plugged or dirty screen is a sign of problems in your pool filtration system and you need to contact your local pool professional.

To clean the filter screen, pull the screen out from inside the Wall Fitting and rinse thoroughly and push back inside the wall fitting.

Whenever cleaning, back washing or repairing the filter, remove the wall fitting and flush out the dedicated line before using the Legend® Platinum.

III. Operation/Periodic Maintenance - (cont.)

2. Tires & Bearings

The tires are designed to protect the bottom of your pool and provide better traction. You need to rotate or replace the tires when edges become rounded.

The Wheel Bearings are warranted free of defects when shipped from Pentair Water Pool and Spa, Inc., and are considered a wear item. A good bearing will spin freely.

3. Roller Rings

Your Sweep Hose has a series of Roller Rings to protect the Sweep Hose. Replace the rings as needed. You can rotate the Roller Rings to prevent flat spots.

4. Debris Bags

Fine Mesh Sand & Silt Bag

The Legend® Platinum comes with a Sand & Silt bag for general use in all pools. We do not recommend using the fine mesh bag to pick up leaves and twigs or other large debris for they have sharp points and edges that can poke holes and eventually rip the bag.

Optional Leaf Bag

The leaf bag is a larger mesh bag made to pick up heavier debris such as leaves, twigs, acorns, etc. This bag can be helpful especially after a storm.

A Helpful Hint: To prolong the life of bags, remove cleaner from pool before adding chemicals.

5. Sweep Hose

The Sweep Hose is provided to help keep the bottom and sides of your pool clean. The Sweep Hose is warranted free of defects when shipped from the factory, and is considered a wear item.

6. Debris Valve

This valve is located under the Debris Bag, it is designed to keep the debris inside the bag. It functions like a check valve to allow the debris to only enter through the bag one way. Replacement is needed when valve begins to stiffen.

E. Back Washing the Pool Filter

Always disconnect the Legend® Platinum from the pool wall before cleaning or back washing the pool filter. After cleaning or back washing, let the pool filtration system run for a minimum of five minutes to flush out the return lines before reconnecting the Legend® Platinum.

F. Storage and Winterizing

Never leave or store the Legend® Platinum in direct sunlight. When storing the Legend® Platinum for the winter, be sure to drain all the water from it. This is important since freeze damage is not covered under the warranty. Also, remove the Wall Fitting.

G. Accessories

1. Sweep Hose Weight

If the sweep hose tends to break the surface of the water therefore squirting nearby windows or innocent bystanders, a weight can be installed to the end of the sweep hose.

(Part # for Hose Weight is EH09C)

2. Leaf Bag (See Debris Bags #4)

IV. TROUBLESHOOTING AND PERFORMANCE TIPS

To insure the best performance from your cleaner, follow the troubleshooting guide listed below.

A. PROBLEMS & SOLUTIONS

Problem: Legend® Platinum doesn't move or moves sluggishly or hangs up on steps.

- Solution:**
1. Be sure filter pump and booster pump are on and working properly. (You may need to clean your pool filter system).
 2. Check the Wall Fitting screen for debris and rinse clean.
 3. Check wheel RPM ([See page 8](#)).
 4. Determine if the Back-Up Valve is cycling. (Hold the valve out of the water and the jet should come on for approx. 30 seconds and shut off for approx. 3 minutes and 30 seconds.)
 5. Check all the Hose connections and Swivels for leaks that can cause loss of water pressure.
 6. Check debris that may be jammed in the gear teeth on one of the front drive wheels. Gently rotate the front wheels backward to dislodge debris.

Problem: Legend® Platinum falling over or lying on it's side.

- Solution:**
1. This usually indicates the bag needs to be emptied.
 2. Check to see if the ballast float (EA20-White or LLA20G-Gray) is leaking by checking if there is water inside. Unscrew by pull back while turning counter-clockwise. When it comes off, shake it and listen for water in float.

Problem: Legend® Platinum will not back up.

- Solution:**
1. Determine if the Back-Up Valve is cycling. (Hold the valve out of the water and the jet should come on for approx. 30 seconds, and shut off for approx. 3 minutes and 30 seconds).
 2. Check the wheel RPM ([See page 8](#)).
 3. Empty the debris bag if full or half full.

Problem: Legend® Platinum will not climb.

- Solution:**
1. Even if your pool doesn't show algae you still need to brush the sides of the pool wall.
 2. Check the wheel RPM ([See page 8](#)).
 3. Reposition the Thrust Jet. Loosen the four screws to adjust the Thrust Jet.

A reminder: The climbing ability of the Legend® Platinum is dependent on the pool's shape and available water pressure. It will climb better in pools without sharp angles or curves in the transition from the pool floor to the pool wall.

Problem: Hoses tangling.

- Solution:**
1. Check the length of the Feed Hose, they may be too long. ([See pages 3-6](#)).
 2. Check to see that the Feed Hose is floating on top of surface. Check hose floats for even spacing.
 3. Twist the Hose Swivels to see if they spin freely and replace any that will not.
 4. Lay out the Feed Hose straight in the full sun to remove any memory.

IV. TROUBLESHOOTING AND PERFORMANCE TIPS

A. PROBLEMS & SOLUTIONS - (cont.)

Problem: Sweep Hose is sucked into the cleaner.

Solution: 1. Adjust the Sweep Hose using the Adjustment Screw located on the bottom of the Swivel Mast. Turn Adjustment Screw clockwise until the Sweep Hose is in a gentle sweeping motion.

Problem: Booster Pump very noisy.

Solution: 1. Make sure Wall Fitting is mounted in pool wall correctly.
2. Make sure Pool Filtration system is working properly.
3. Contact your local Pool Professional - possible Booster Pump problem.

Problem: Sweep Hose breaks surface and sprays nearby windows, patio decks and bystanders.

Solution: 1. Adjust Sweep Hose to a gentle sweeping motion.
2. Add optional Sweep Hose weight (See page 10).

LEGEND® PLATINUM PARTS LIST

Diagram #	Part #	Description	Quantity
1	LLU5PM	Top Cover - Gray	1
2	LLU145N	Main Frame - White	1
2	LLU145NG	Main Frame - Gray	1
3	EU10N	Bottom Cover - White	1
3	LLU10NG	Bottom Cover - Gray	1
4	LLU6	Feed Mast w/O-Ring - White	1
4	LLU6G	Feed Mast w/O-Ring - Gray	1
5	EC86	Turbine Drive Shaft - Complete	1
6	EC83	Turbine Spacers	1
7	EC80	Turbine Bearings - Gray	2
8	EA40	Turbine Shaft Shield - White	1
8	LLA40G	Turbine Shaft Shield - Gray	1
9	EC110	Turbine Cover w/Elbow - White	1
9	LLC110PM	Turbine Cover w/Elbow - Gray	1
10	EX120	Turbine Cover Hose - 9" length - White	1
10	LLX120	Turbine Cover Hose - 9" length - Gray	1
11	EC120	Venturi Jet - Hose - 7 3/4" length - White	1
11	LLC120G	Venturi Jet - Hose - 7 3/4" length - Gray	1
12	EB5L	Sweep Hose - Complete - White	1
12	LLB5G	Sweep Hose - Complete - Gray	9
13	EB10	Sweep Hose - Wear Ring	1
14	EB25	Sweep Hose - Jet w/Collar - White	1
14	LLB25PM	Sweep Hose - Jet w/Collar - Gray	1
15	EB20	Sweep Hose - Adjustment Screw - White	1
15	LLB20G	Sweep Hose - Adjustment Screw - Gray	1
16	EA20	Ballast Float - White	1
16	LLA20PMG	Ballast Float - Gray	17
17	EH07	Sweep Hose - Hose Sleeve - White	17
17	LLH07PM	Sweep Hose - Hose Sleeve - Gray	1
18	EU15	Coarse Mesh Bag - White Collar	1
18	EU15G	Coarse Mesh Bag - Gray Collar	1
19	EU16	Fine Mesh Bag - White Collar	1
19	EU16G	Fine Mesh Bag - Gray Collar	1
20	EU9	Debris Valve	1
21	EU7	O-Ring for Feed Mast	2
22	E18	O-Ring for Thrust Jet	2
23	EC130	Thrust Jets - White	2
23	LLC130G	Thrust Jets - Gray	2
24	EC135	Thrust Jet Plates - White	2
24	LLC135G	Thrust Jet Plates - Gray	4
25	EC65	Axle - Large Wheels	4
26	EC70	Axle Plate	8
27	EC45	Axle - Lock Washer	4
28	LLC6PM	Wheel w/out Bearings - White	4
28	LLC6PMG	Wheel w/out Bearings - Gray	4

LEGEND® PLATINUM PARTS LIST

Diagram #	Part #	Description	Quantity
29	LLC60PM	Wheel Bearings Only - Gray	8
30	E10	Back-Up Valve - White	1
30	LL10PM	Back-Up Valve - Gray	1
31	EC55	Wheel Screw - Plastic - White	4
31	LLC55PM	Wheel Screw - Plastic - Gray	4
32	LLC1PM	Wheel - Rubber Tire - White	4
32	LLC1PMG	Wheel - Rubber Tire - Gray	4
33	EB15	Hose Clamp	5
34	EC40	Screw	8
35	LLD50	Feed Hose - clear soft - 10'	1
35	LLD50PM	Feed Hose - Gray soft - 10'	1
36	ED10P	Float - Feed Hose - White	10
36	LLD10PM	Float - Feed Hose - Gray	10
37	LLD45	Feed Hose - 10' - White	2
37	LLD45PM	Feed Hose - 10' - Gray	2
38	ED05	Swivel - Feed Hose - White	2
38	LLD05PM	Swivel - Feed Hose - Gray	2
39	LLU1	Adapter Hose - 8-1/2" - White	1
39	LLU1PM	Adapter Hose - 8-1/2" - Gray	1
40	ED15	Mender Nut - plastic - White	8
40	LLD15PM	Mender Nut - plastic - Gray	8
41	LLW22PM	Wall Fitting - Gray	1
41	EW22	Wall Fitting - White	1
41	LL25PM	Pressure Relief Valve - Gray	1
41	E25	Pressure Relief Valve - White	1
42	E24	Screen - Wall Fitting	1
43	LL23PM	Quick Disconnect Adapter - Gray	1
43	E23	Quick Disconnect Adapter - White	1
44	EC64	Wheel - Plastic Washer	4
45	EG15	Gears - for Back-Up Valve	1
46	EC131	Thrust Jet Repair Kit includes: (White) E18, EC130, EC135	1
46	LLC131G	Thrust Jet Repair Kit includes: (Gray) E18, LLC130G, LLC135G	1
47	EU30	Screw for EA40 or LLA40G and EC110 or LLC110PM	5
48	EU76	Axle Bolt	8
49	EU147	Snap Fit Vac Tube Posts - White	2
49	LLU147G	Snap Fit Vac Tube Posts - Gray	2
50	EU79	Nut & Bolt - Feed Mast to Vac Tube	1
51	EU80	Venturi Jet - White	2
51	LLU8G	Venturi Jet - Gray	2
52	EU80	Screw - Cover to Frame	2
53	LLU81PM	Front Bumper - White	1
53	LLU81PMG	Front Bumper - Gray	1

LEGEND® PLATINUM EXPLODED VIEW

