

THE AIRPLANE

10.2090

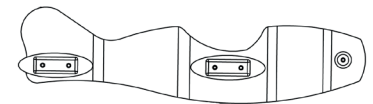
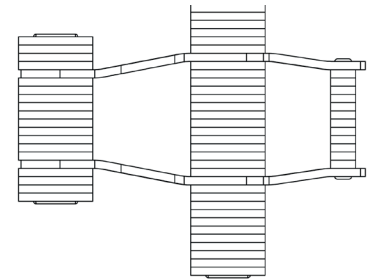
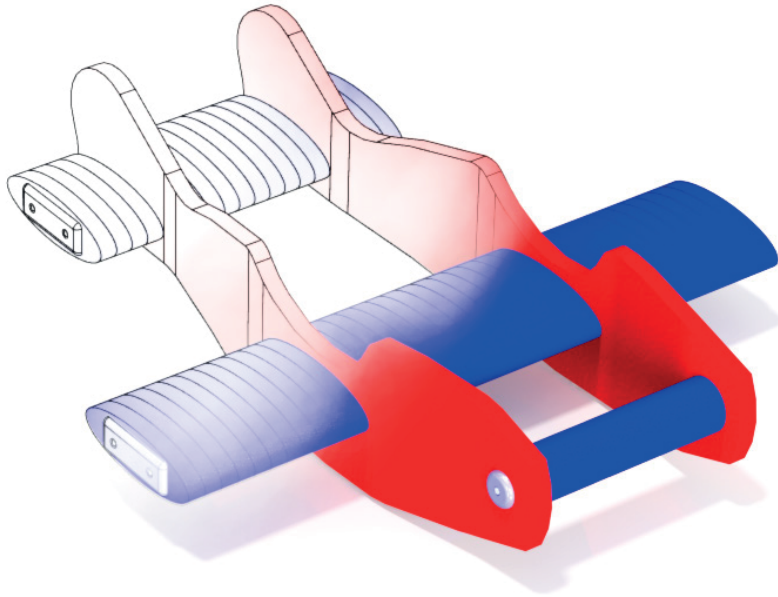

⚠ WARNING:

- 1- THIS PRODUCT IS TO BE USED IN A PUBLIC SWIMMING POOL UNDER THE SUPERVISION OF QUALIFIED PERSONNEL
- 2- NEVER STAND UP ON THIS PRODUCT
- 3- THIS PRODUCT IS TO BE USED IN A MINIMUM WATER DEPTH OF 4 FEET AND AT DISTANCE OF 6.5 FEET FROM THE SIDES OF THE POOL
- 4- WHEN NOT IN USE, DO NOT LEAVE IN DIRECT SUNLIGHT
- 5- STORE IN A DRY AND CLEAN SPACE
- 6- SAFETY HAZARD IF NOT ASSEMBLED CORRECTLY. TO BE ASSEMBLED BY A QUALIFIED ADULT ONLY.
- 7- THIS IS NOT A LIFESAVING DEVICE. DO NOT LEAVE CHILD UNATTENDED WHILE DEVICE IS IN USE.

PRODUCT USE :

CONGRATULATIONS! YOU HAVE JUST PURCHASED ONE OF OUR INNOVATIVE AND SAFE, TOP-OF-THE-LINE FOAM TOYS. IT WILL PROVIDE LOADS OF FUN FOR MANY YEARS TO COME! KIDS CAN IMAGINE THAT THEY ARE READY FOR TAKE-OFF! WITH KIDS SITTING ON THE WINGS AND THE BACK OF THE PLANE AND BY USING KICKING POWER, THEY CAN PROPEL THEMSELVES AROUND THE POOL AND WITH A GOOD IMAGINATION, AROUND THE WORLD!

2 - WE HAVE A COMPLETE LINE OF FOAM TOYS. TO SEE OTHER MODELS, PLEASE VISIT WWW.NORDESCO.COM FOR MORE INFORMATION.

NORDESCO inc
CANADA : 514-270-5603
1-866-420-6478
USA : 1-866-560-3715
WWW.NORDESCO.COM

REQUIRED TOOLS :
(NOT INCLUDED)

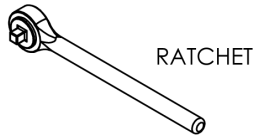

ASSEMBLY :

STEP 1

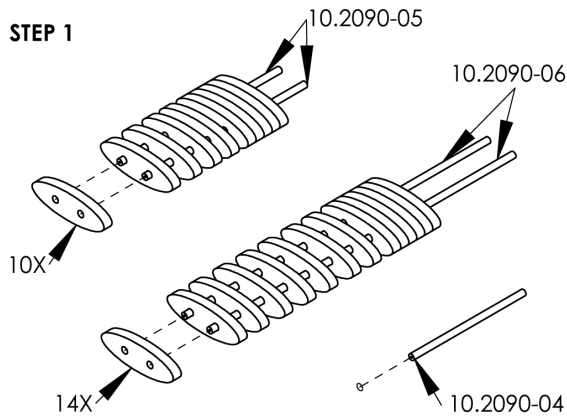

STEP 2

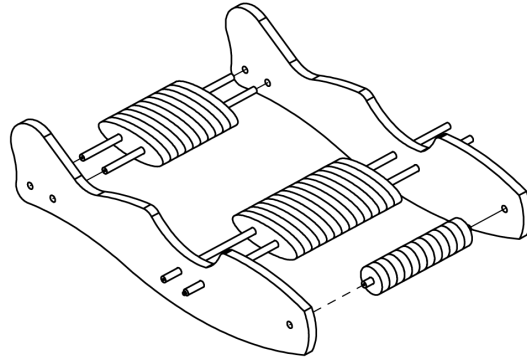

STEP 3

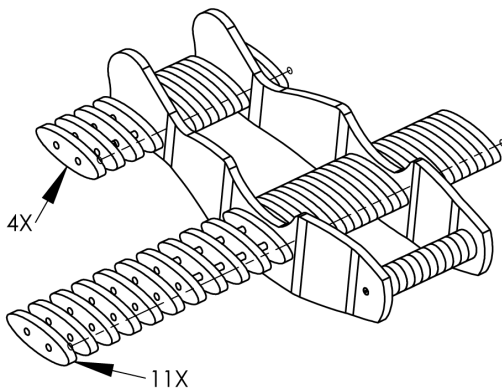

STEP 4

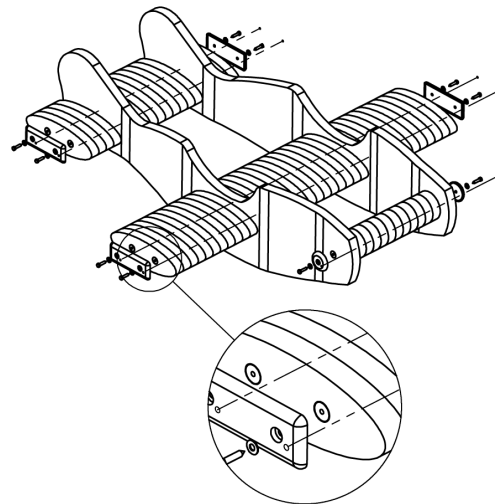

PARTS INCLUDED :

10X

(5/16 X 2.5")



4X

10.SAS.113

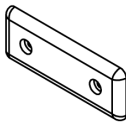

1X

10.2090-04
(21")

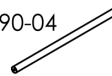

2X

10.2090-01

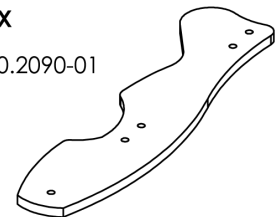

10X

(5/16")



54X

13.5" OVAL COLOR A

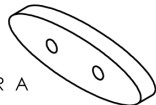

2X

10.2090-05
(30")

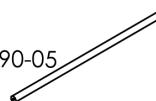

2X

10.SAS.112

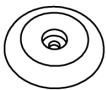

12X

4.5" CIRCLE COLOR A



2X

10.2090-06
(57")

