

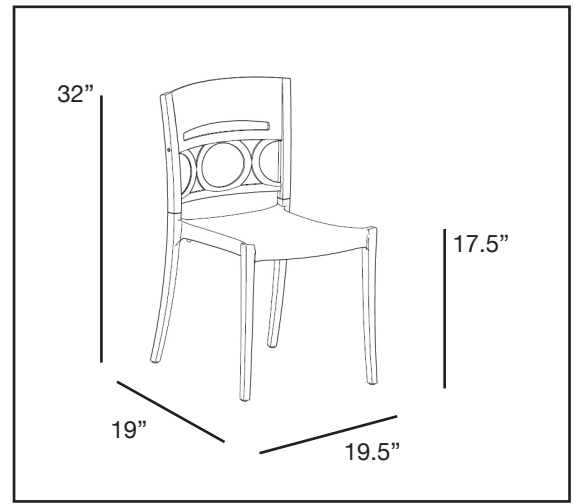

Moon Stacking Chair



Product Specifications

Product Description	Reference Number	Color	UPC Code 014306	Weight Each (lbs.)	Master Pack	Master Pack Volume (cu. ft)	
Moon Stacking Chair	XA649096	Glacier White/Linen	917566	9.77	16	36.94	
	XA649196	Storm Blue/Linen	917573	9.77	16	36.94	
	XA649282	Cactus Green/Linen	917580	9.77	16	36.94	
	XA650579	Titanium Gray/Charcoal	917597	9.77	16	36.94	
	US649096	Glacier White/Linen	917566	10.07	4	15.21	
	US649196	Storm Blue/Linen	917573	10.07	4	15.21	
	US649282	Cactus Green/Linen	917580	10.07	4	15.21	
	US650579	Titanium Gray/Charcoal	917597	10.07	4	15.21	

Features & Benefits Warranty: 3 Yrs.

- Passes ASTM F 1561 Class B standard for safe commercial outdoor use.
- Contemporary two color rendition of a traditional cast design of the antique world.
- Low backrest with a wide ergonomic seat.
- Trendy colors to brighten the outdoor design scheme.
- Stacks for easy storage.
- Easy to handle and move around patios and terraces.
- Can easily be cleaned with soap and water.
- Rated to 300 lbs. for safe use in commercial environments.



Glacier White/
Linen



Storm Blue/
Linen



Cactus Green/
Linen



Titanium Gray/
Charcoal

